

# 110-400 SM

Smooth Side Wall  
Smooth Top  
Continuous Thread  
110mm Diameter  
400 Thread Profile  
Lined or Unlined



## OPTIONS

- Available in standard or custom colors
- Low minimum order quantities, safety stock program available
- High speed lining capabilities with a variety of lining materials including heat induction, foam and pressure sensitive
- Round or tri-tab easy-open liners
- Industry's best lead times

## SHIPPING INFORMATION

- Carton quantity: 270
- Carton packing: Tumble
- Pallet quantity: 8,100
- Truckload quantity: 243,000
- Carton weight (lbs): 15.5
- Pallet weight (lbs): 485
- Carton size: 24x16x14"
- Pallet size: 40x48x91"
- Freight class: 150

## STANDARD OR CUSTOM COLORS



PMS 185      PMS 3435      PMS 662C      PMS 2685



PMS 1665      PMS 10388      BLACK      WHITE



PMS 110C

# 110-400 SM

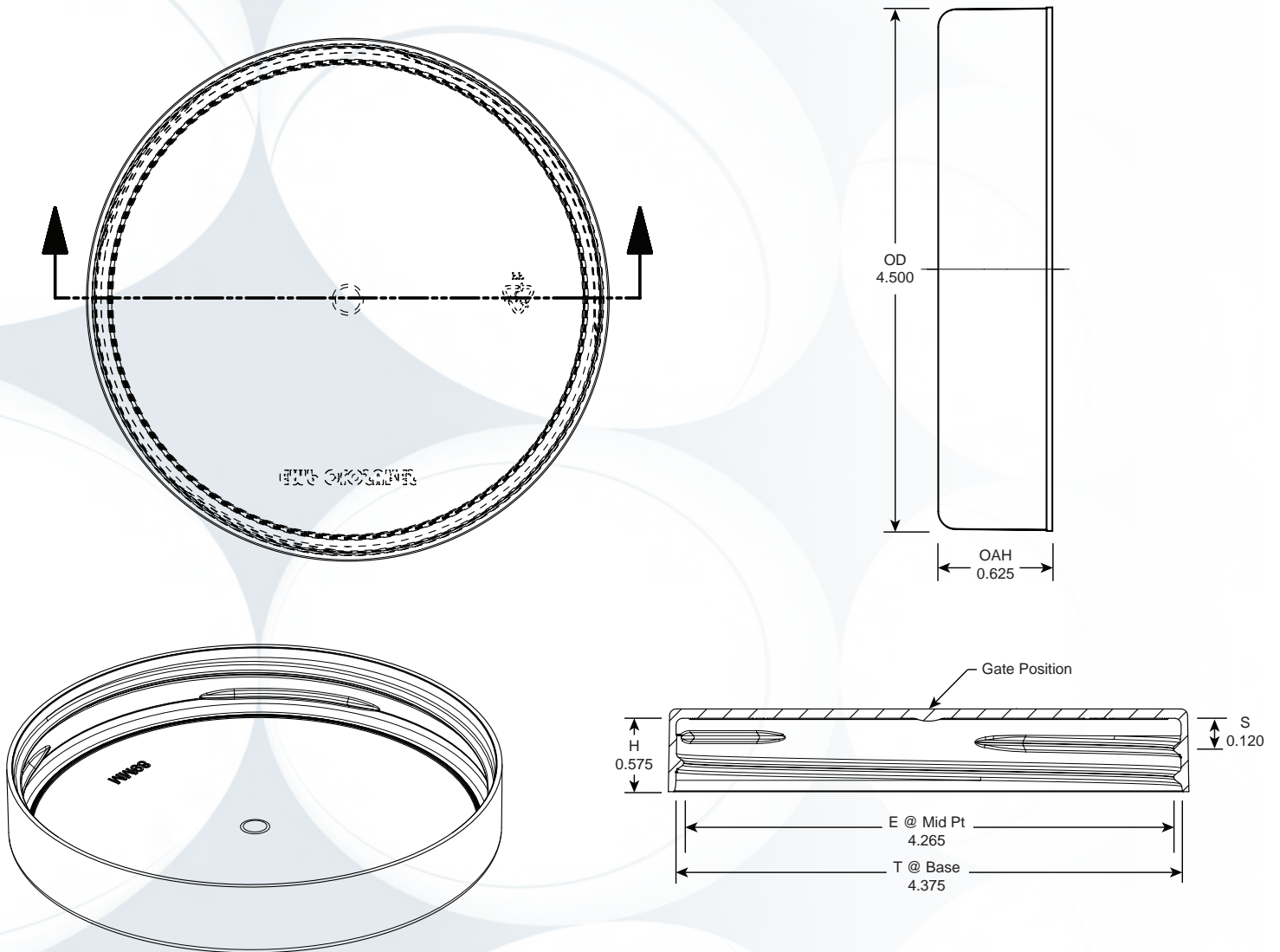

- Country of Origin is the USA and Manufacturing location is Erie, PA
- To maintain the quality of this product, it is recommended that product should be stored in its original packaging; away from any source of local heating and humidity; away from direct sunlight; under 30°C and dry conditions. It is recommended to allow product to reach operating temperature 24 hours before use.
- Products must be used within 12 months from the production date. Stocks should be in rotation so that first delivery is used first and last delivery is used last.

Inch tolerances (unless specified) General: +/- .010 "/>		 6020 West Ridge Road Erie, Pennsylvania 16506 (814) 838-7914 Fax (814) 838-7411
Number of turns: 1.25		
Pitch (TPI): 5	Max Deck Dip: 0.150	110-400 SM
Material: PP		Erie Molded Packaging, Inc.
This drawing is the exclusive property of Erie Molded Packaging, Inc. and may not be reproduced without the expressed written consent of Erie Molded Packaging, Inc.		Date: November 21, 2016
		Sheet: 01 of 01